

Figure 4-9 (C). Beacon transmitting circuit—functional diagram (mushroom) (sheet 1 of 2) (U).

ORD G296681

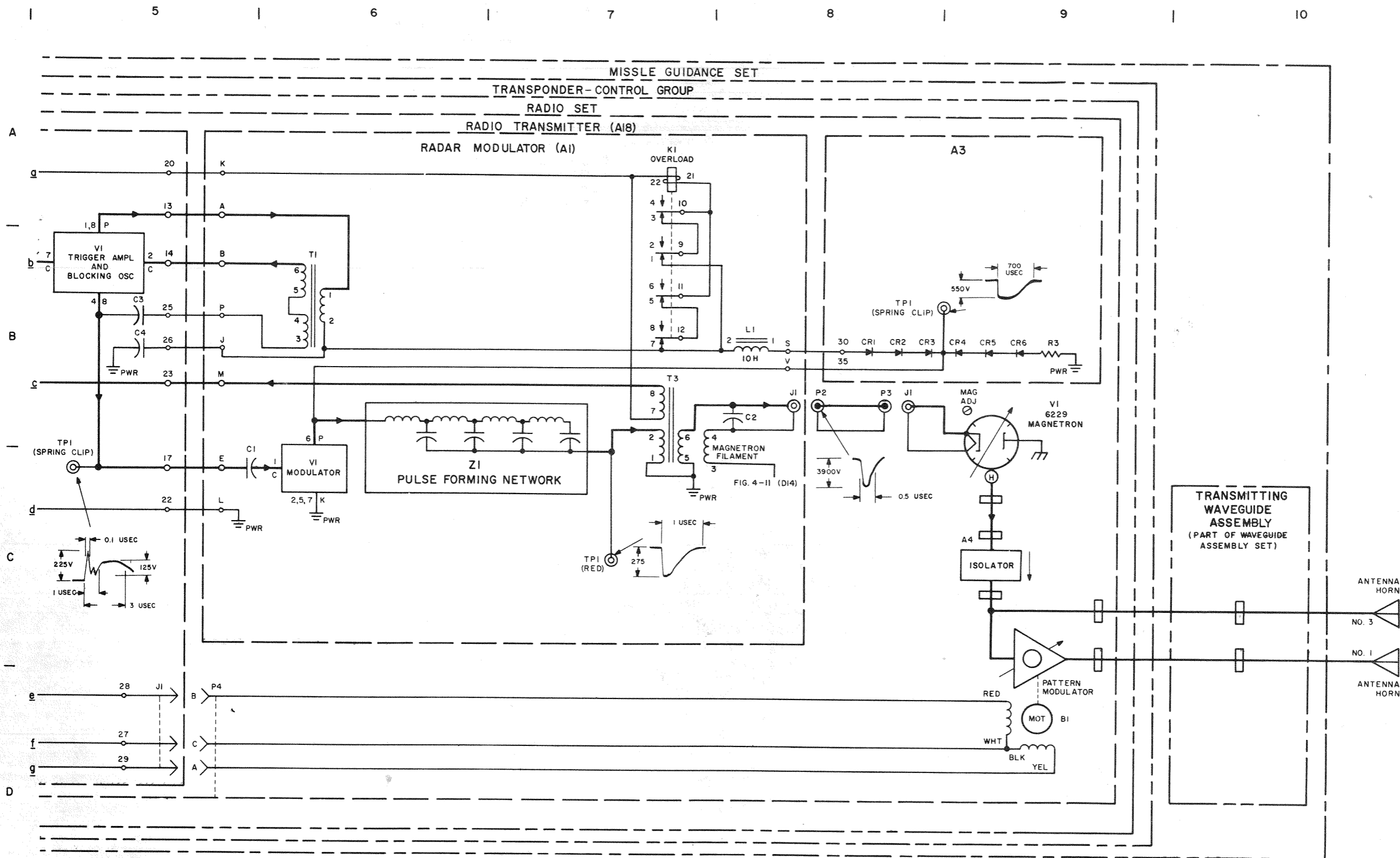

Figure 4-9 (C). Beacon transmitting circuit—functional diagram (mushroom) (sheet 2 of 2) (U).

ORD G296682

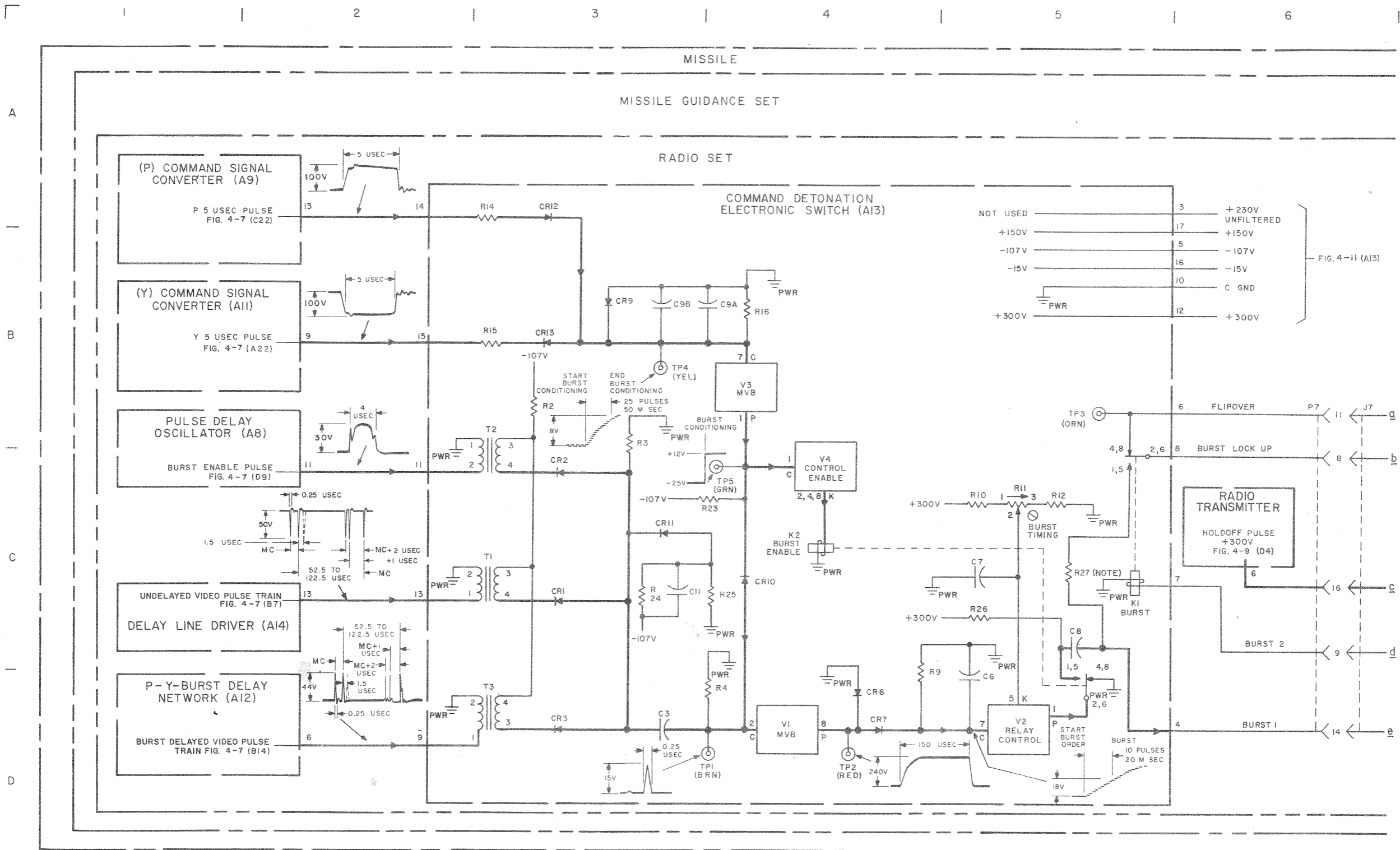

Figure 4-10 (C). Detonation command circuit—functional diagram (mushroom) (sheet 1 of 3) (U).

ORD G296678

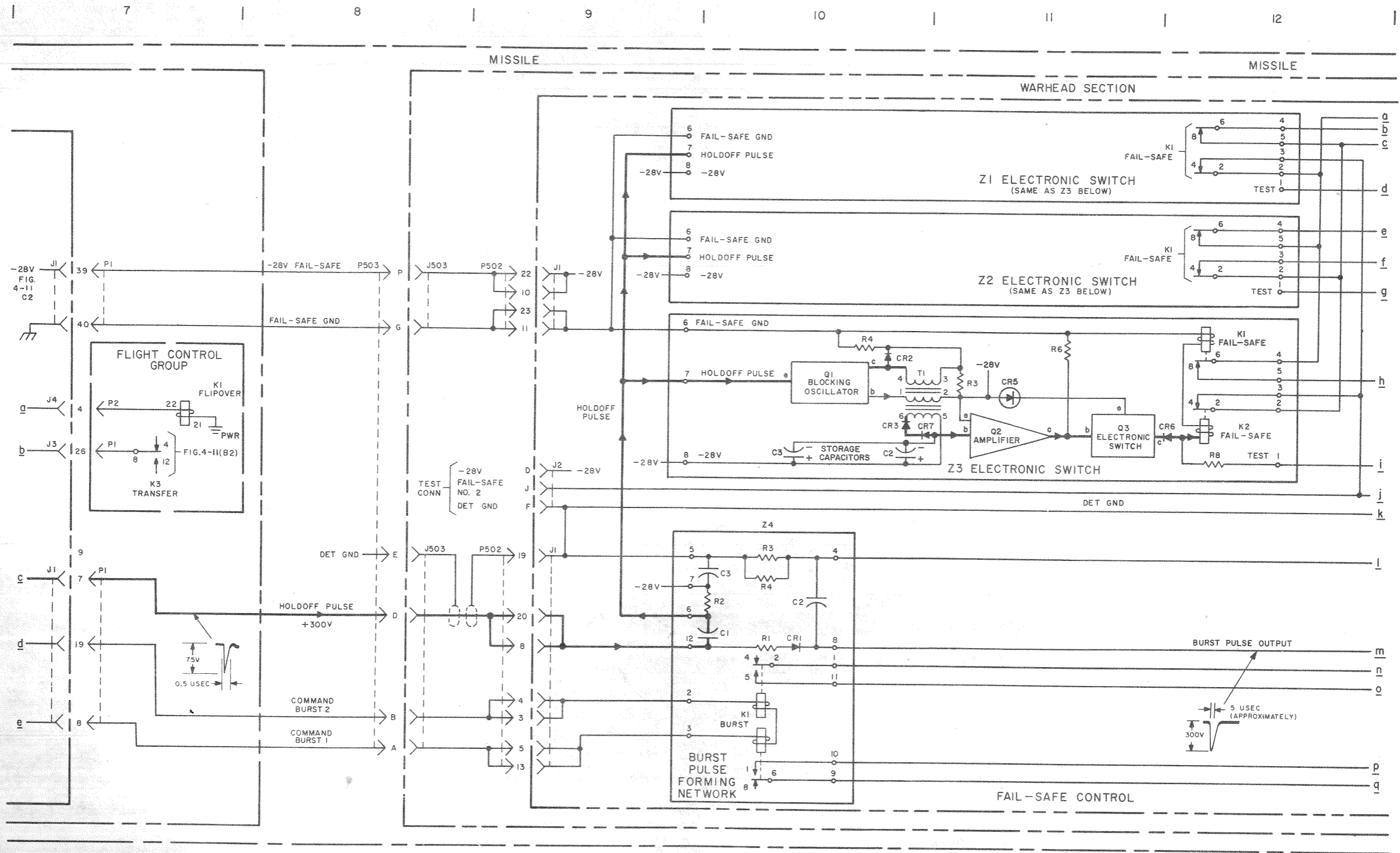

Figure 4-10 (C). Detonation command circuit—functional diagram (mushroom) (sheet 2 of 3) (U).

ORD G296679

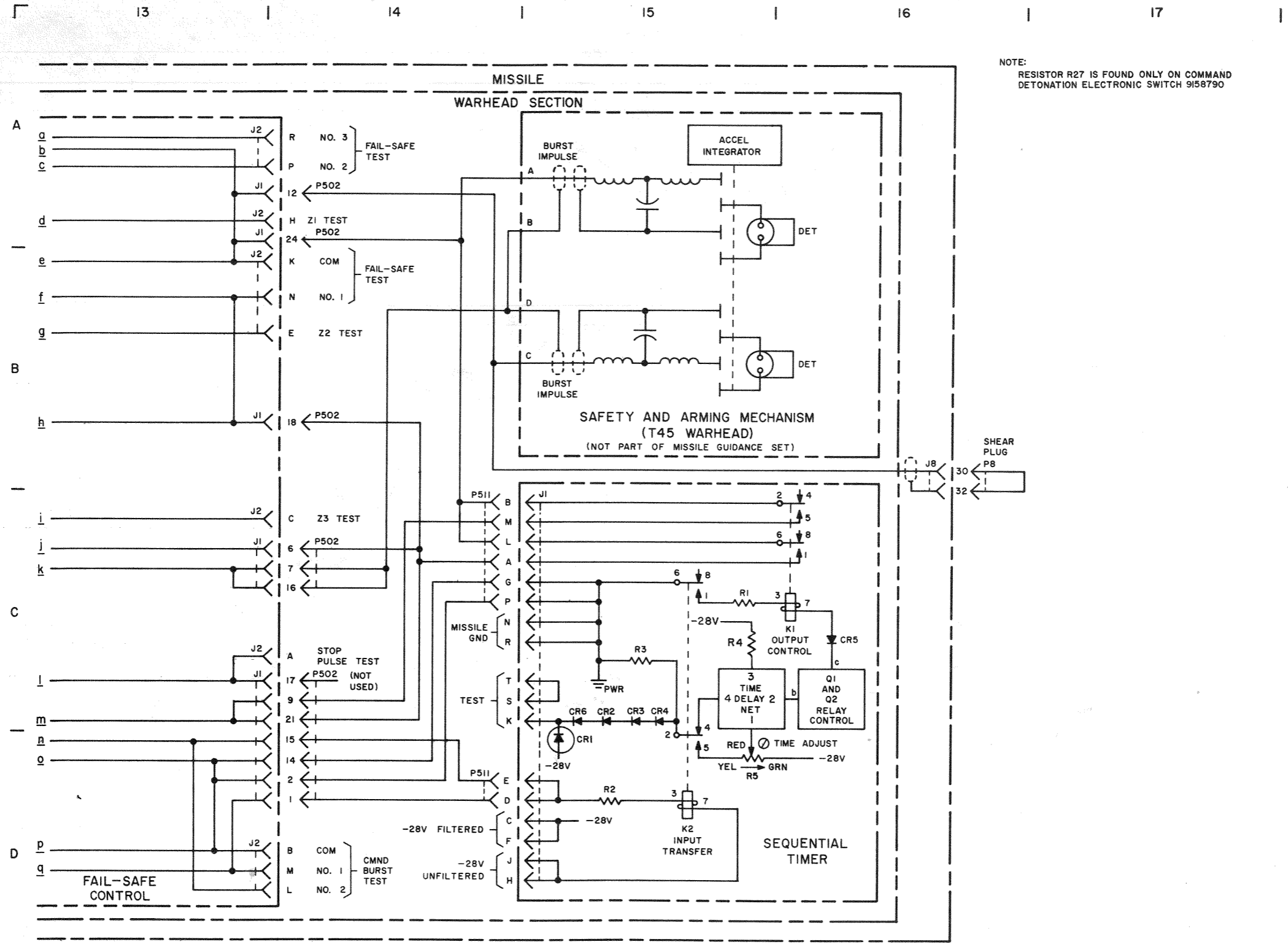

Figure 4-10 (C). Detonation command circuit—functional diagram (mushroom) (sheet 3 of 3) (U).

ORD G296680

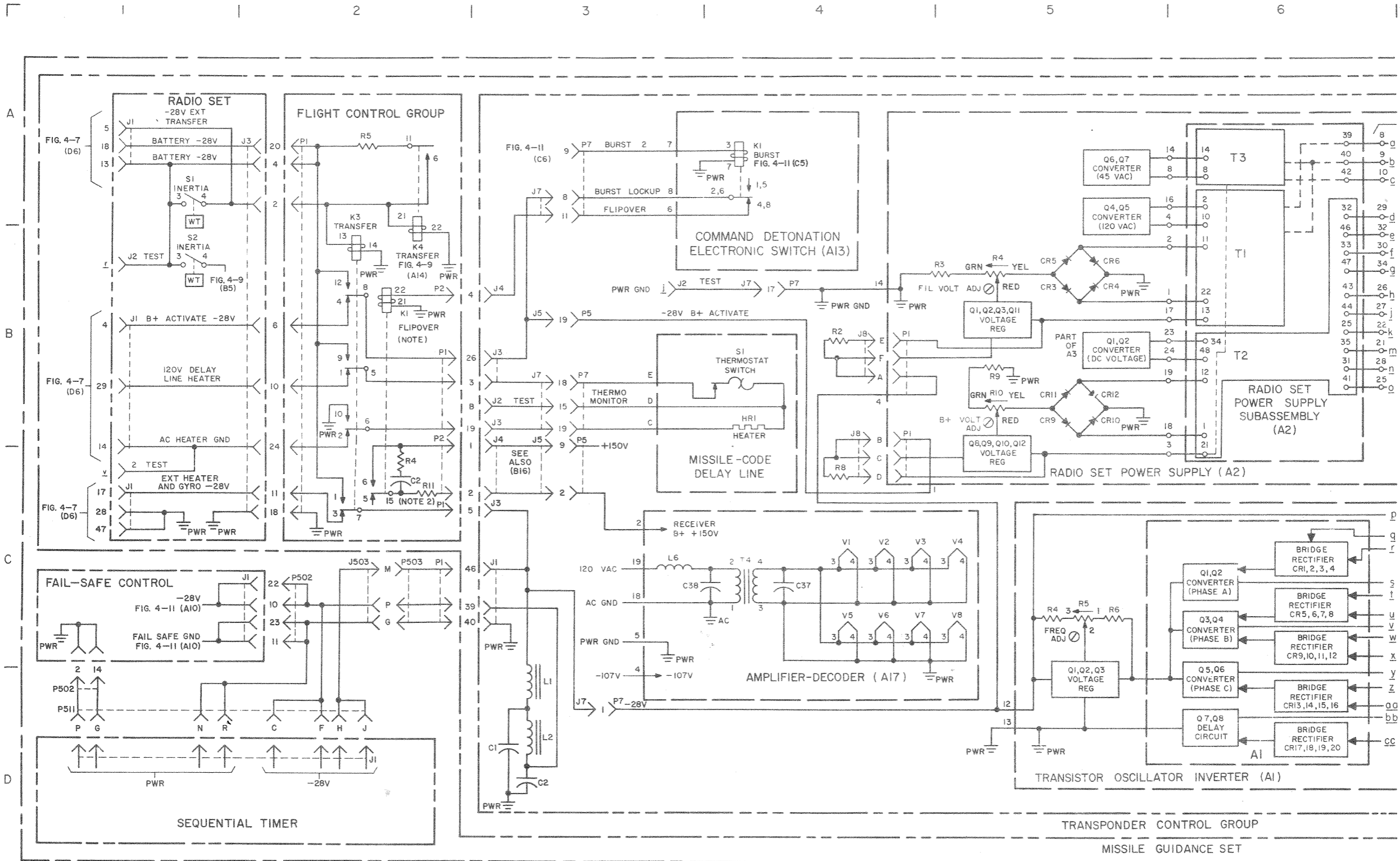

Figure 4-11 (C). Power supply and distribution circuit—functional diagram (mushroom) (sheet 1 of 3) (U).

ORD G296521

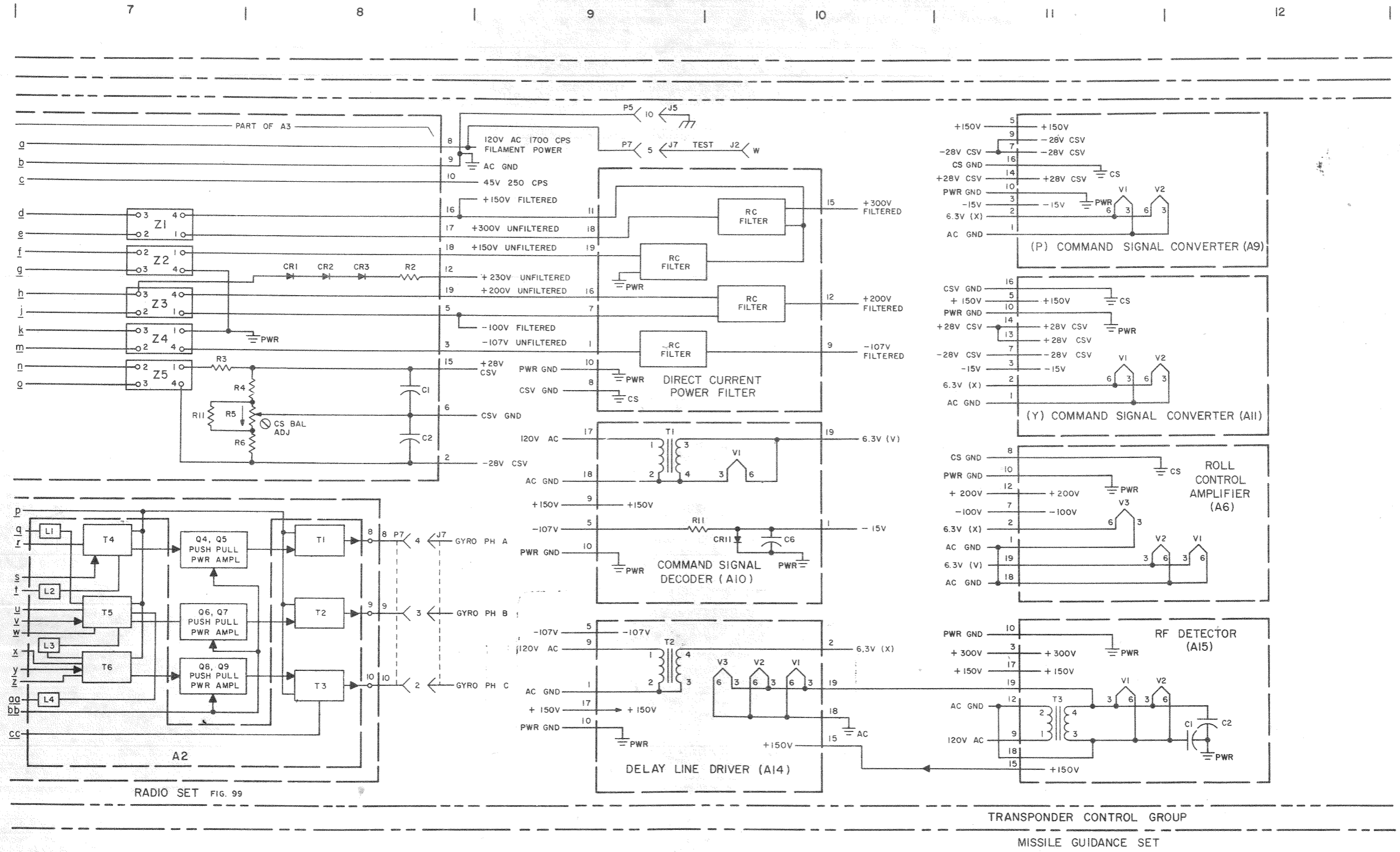

Figure 4-11 (C). Power supply and distribution circuit—functional diagram (mushroom) (sheet 2 of 3) (U).

ORD G296522

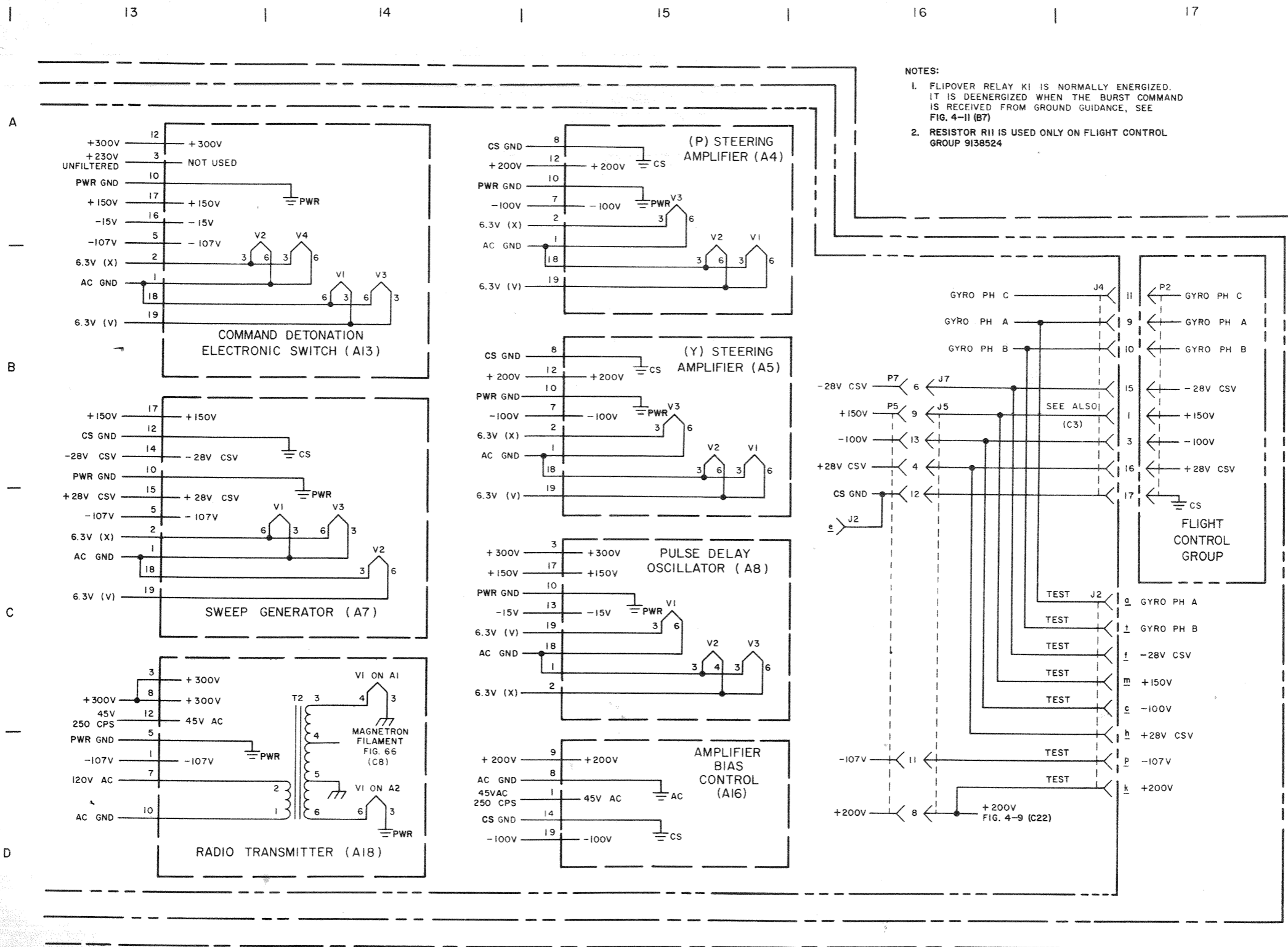

Figure 4-11 (C). Power supply and distribution circuit—functional diagram (mushroom) (sheet 3 of 3) (U).

ORD G296523



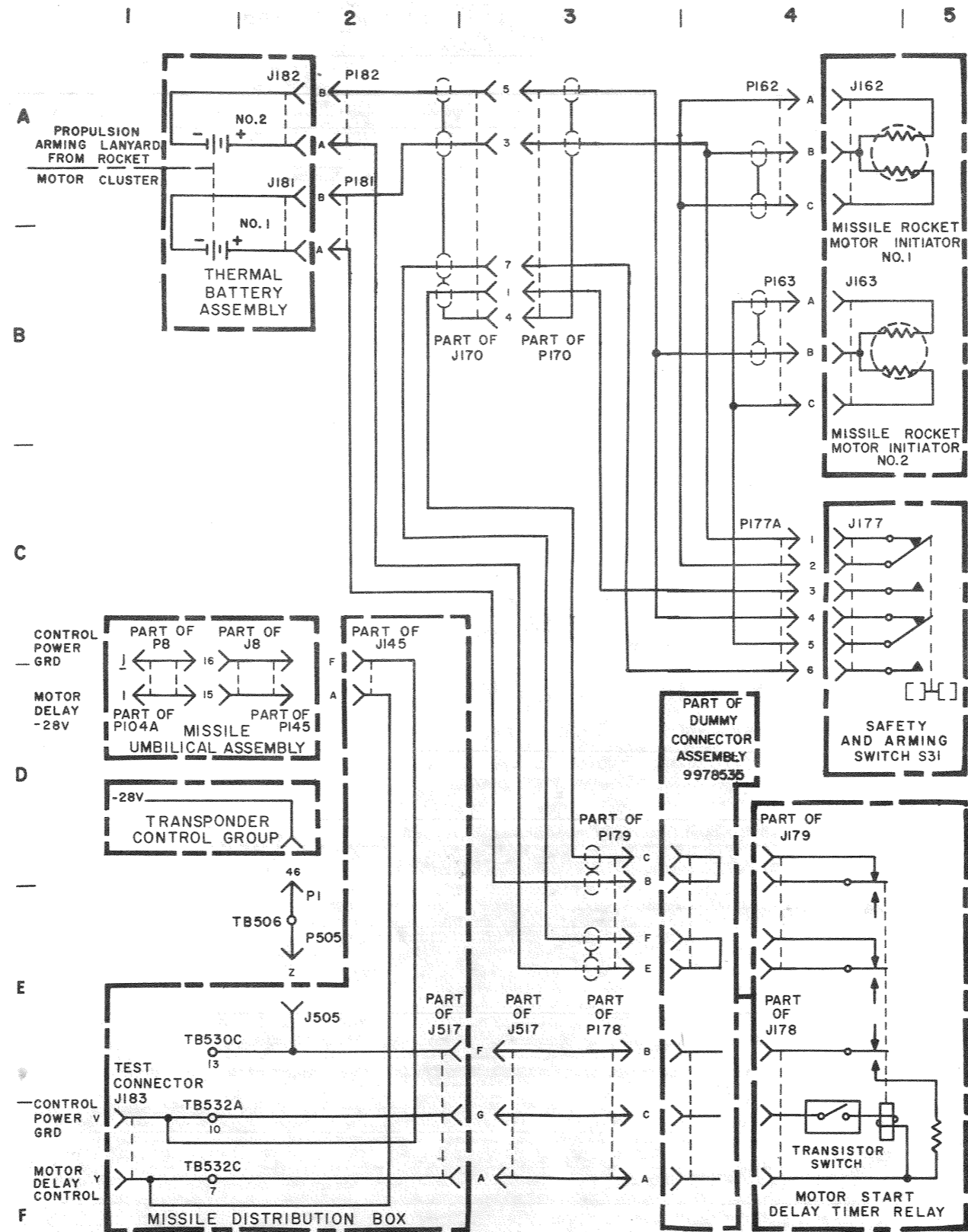

Figure 4-12 (U). Missile propulsion system (U).

ORD G253024

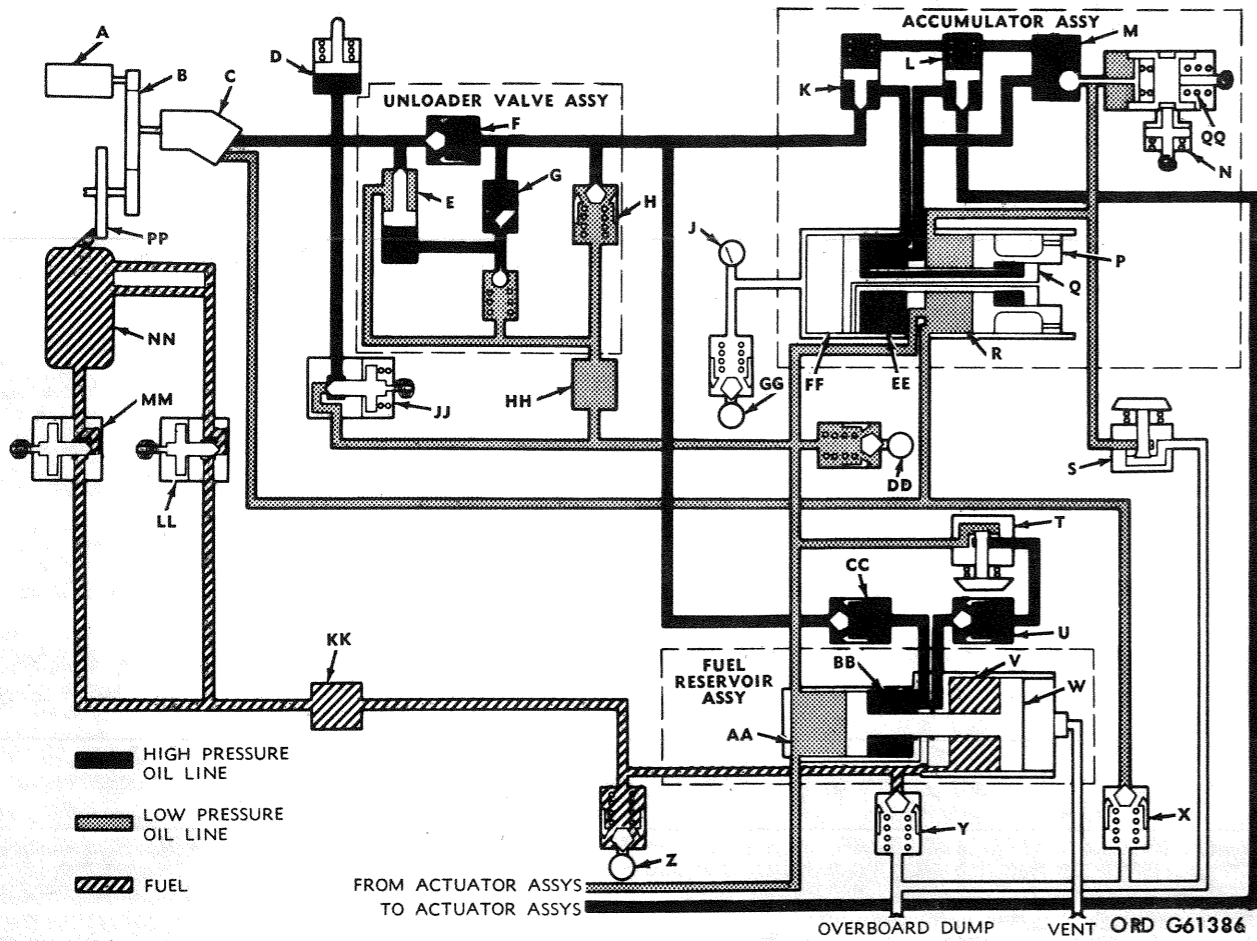

Figure 4-13 (U). Accessory power supply hydraulic system—functional schematic (U).

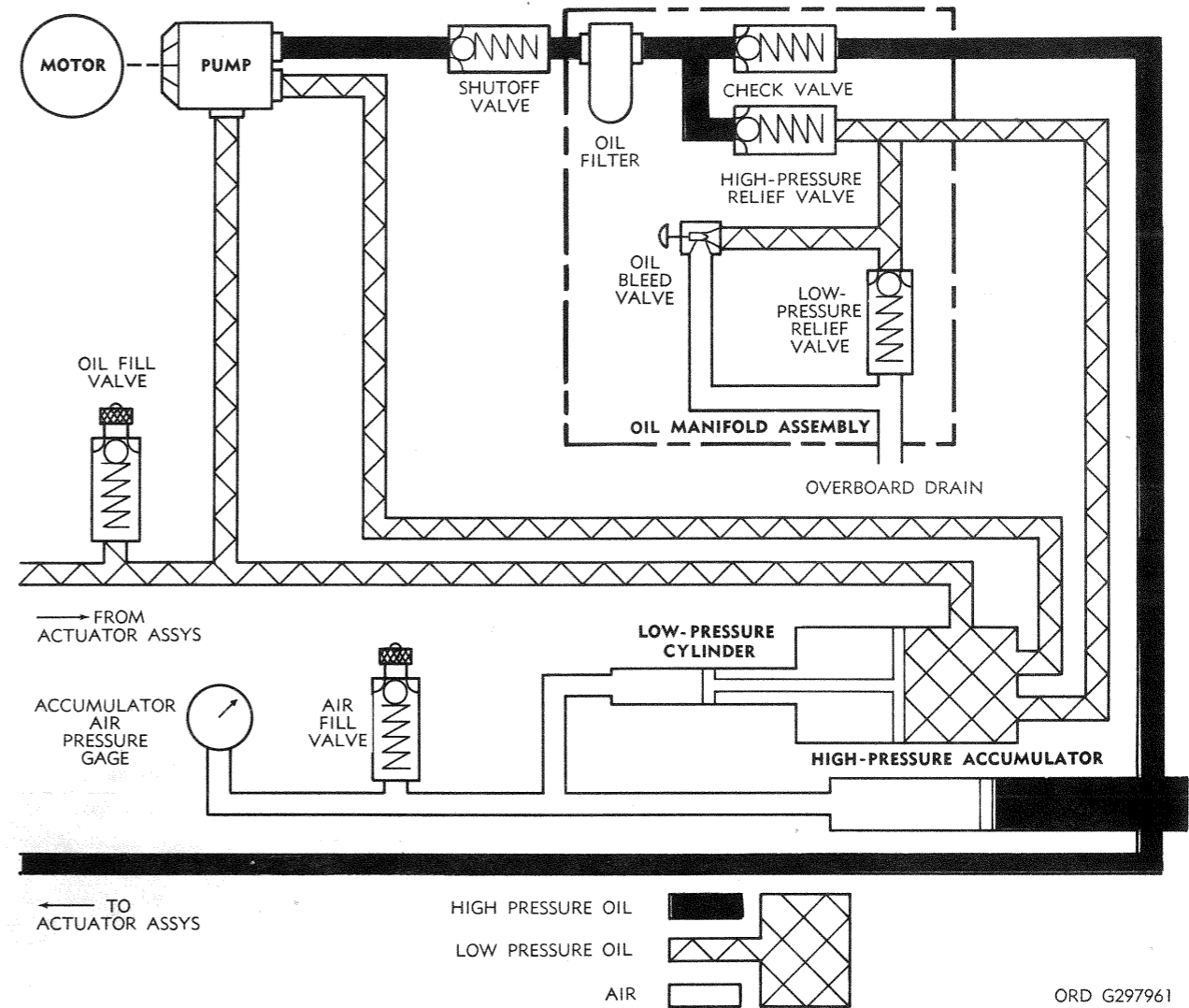
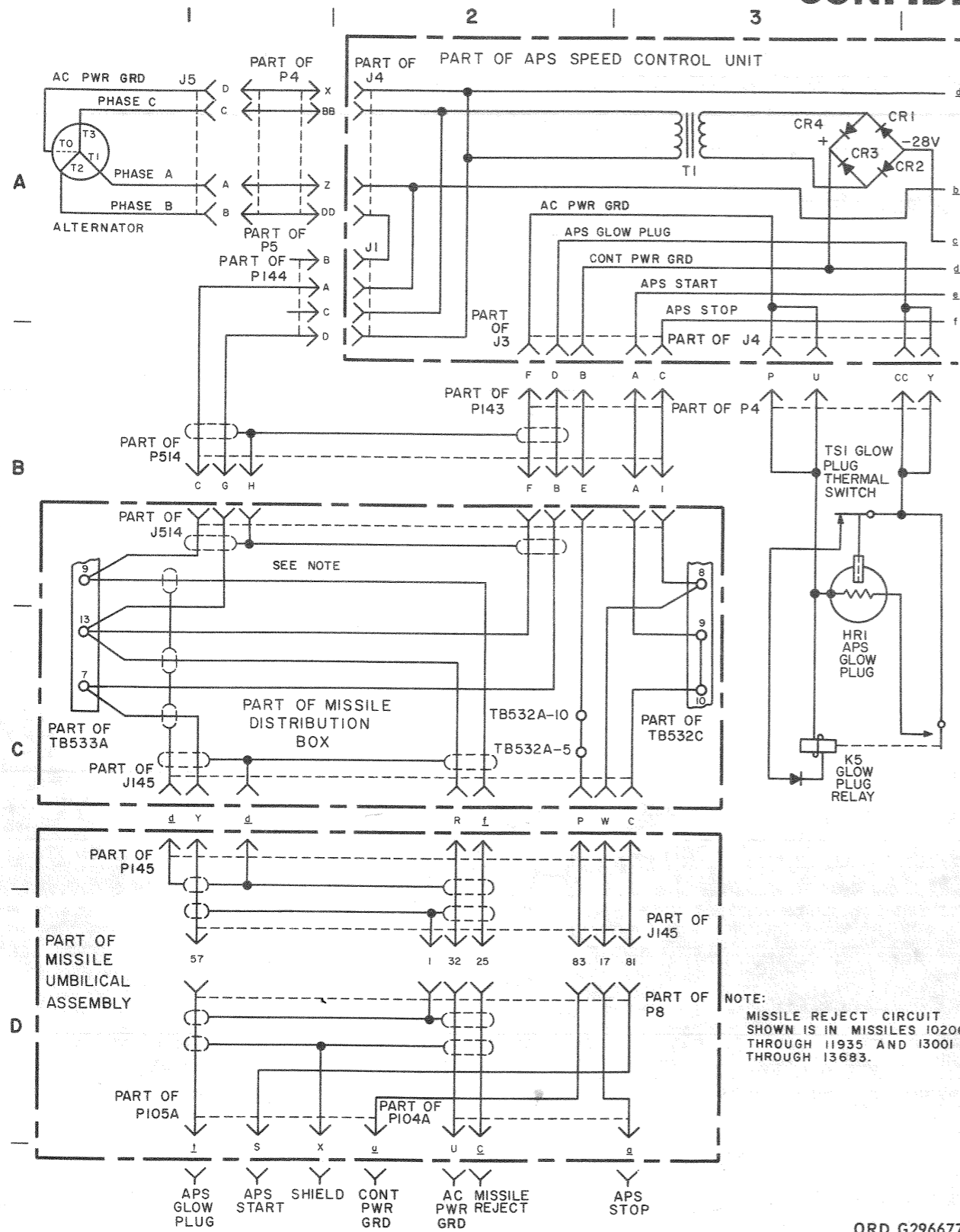
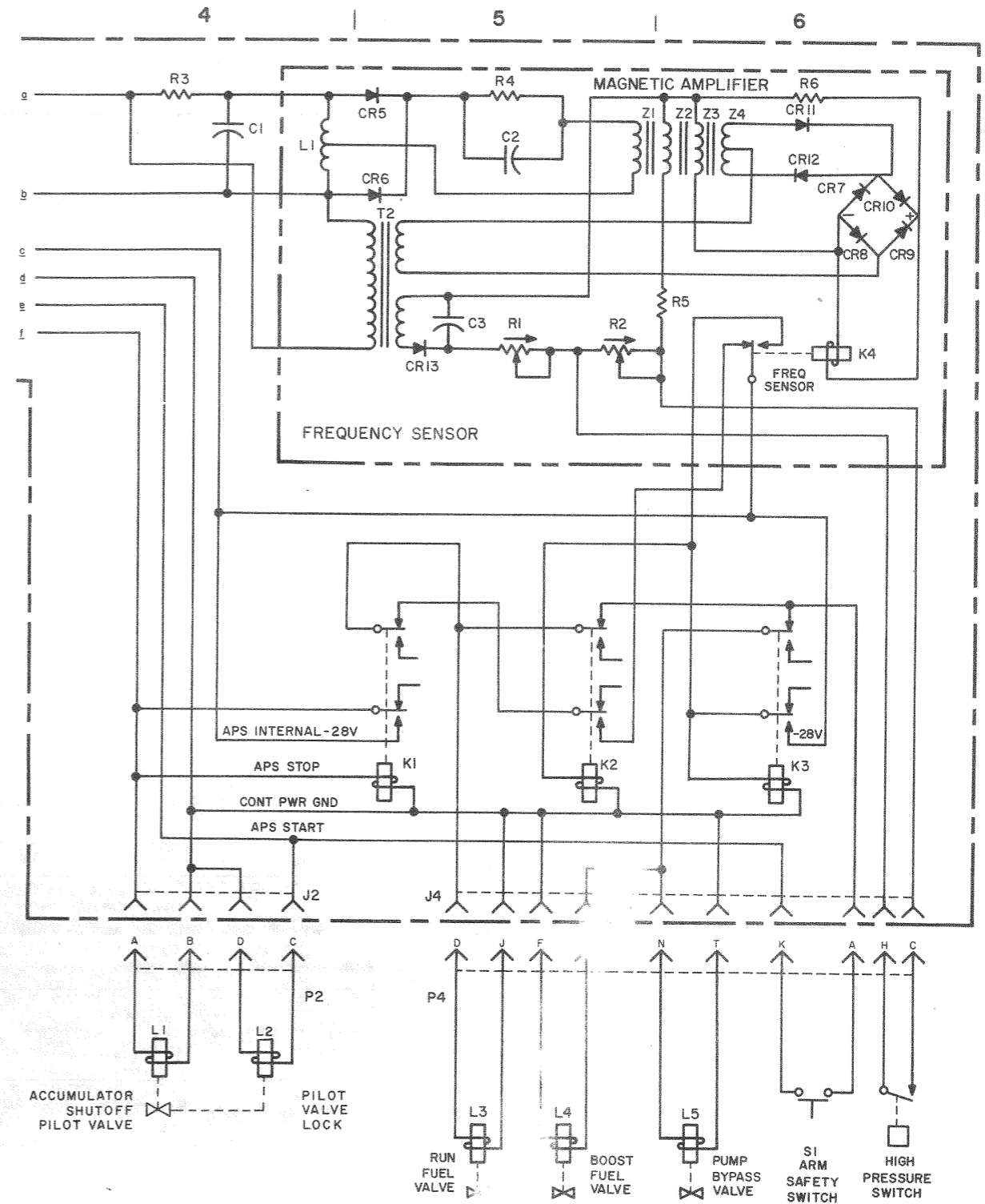

Figure 4-14 (U). Hydraulic pumping unit—hydraulic schematic (U).



ORD G296677

Figure 4-15 (U). Accessory power supply 9032190 electrical control system—functional schematic (sheet 1 of 2) (U).



ORD G61213

Figure 4-15 (U). Accessory power supply 9032190 electrical control system—functional schematic (sheet 2 of 2) (U).

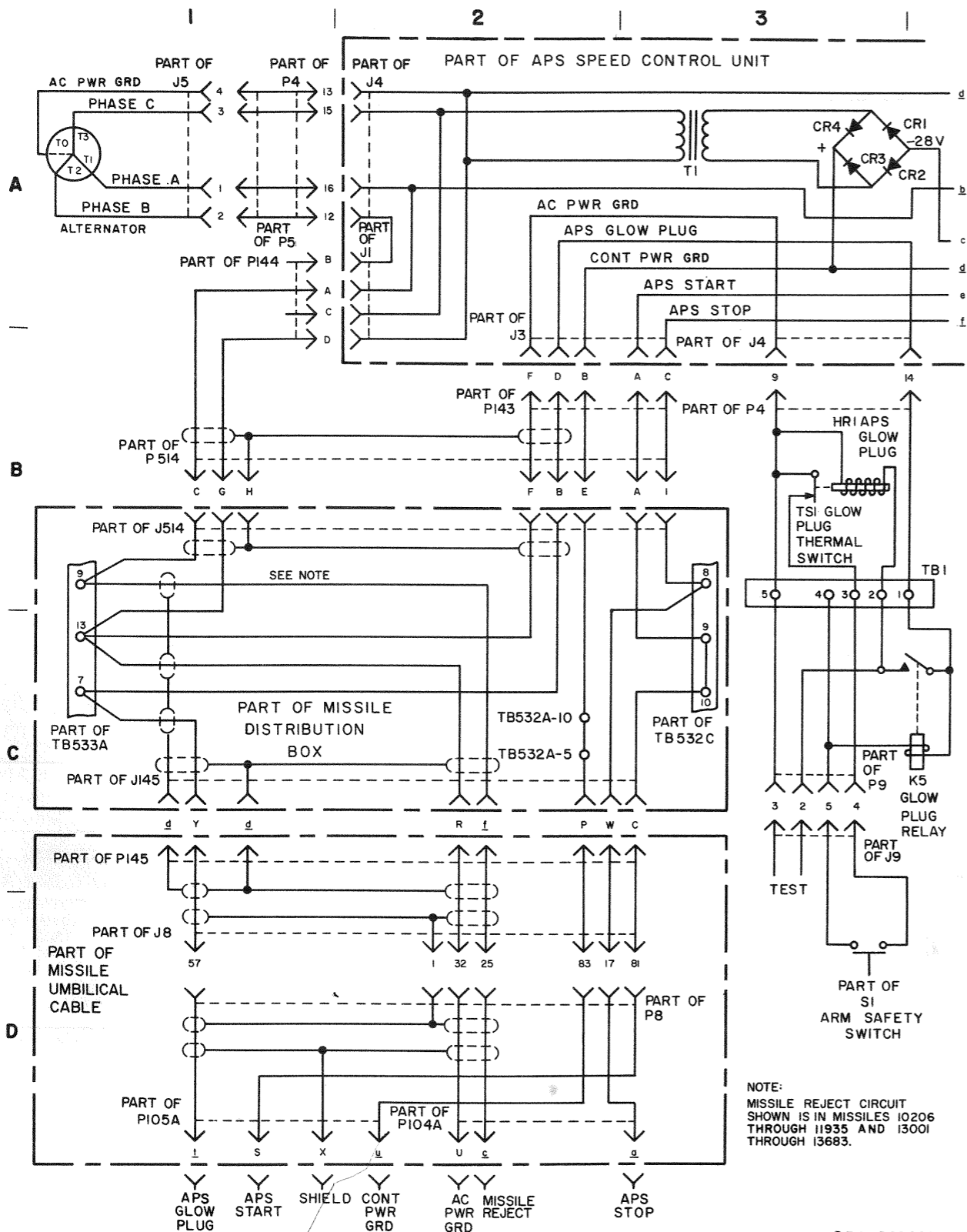

Figure 4-16 (U). Accessory power supply 9030900 electrical control system—functional schematic (serial numbers prior to 69-3632) (sheet 1 of 2) (U).

ORD G296676

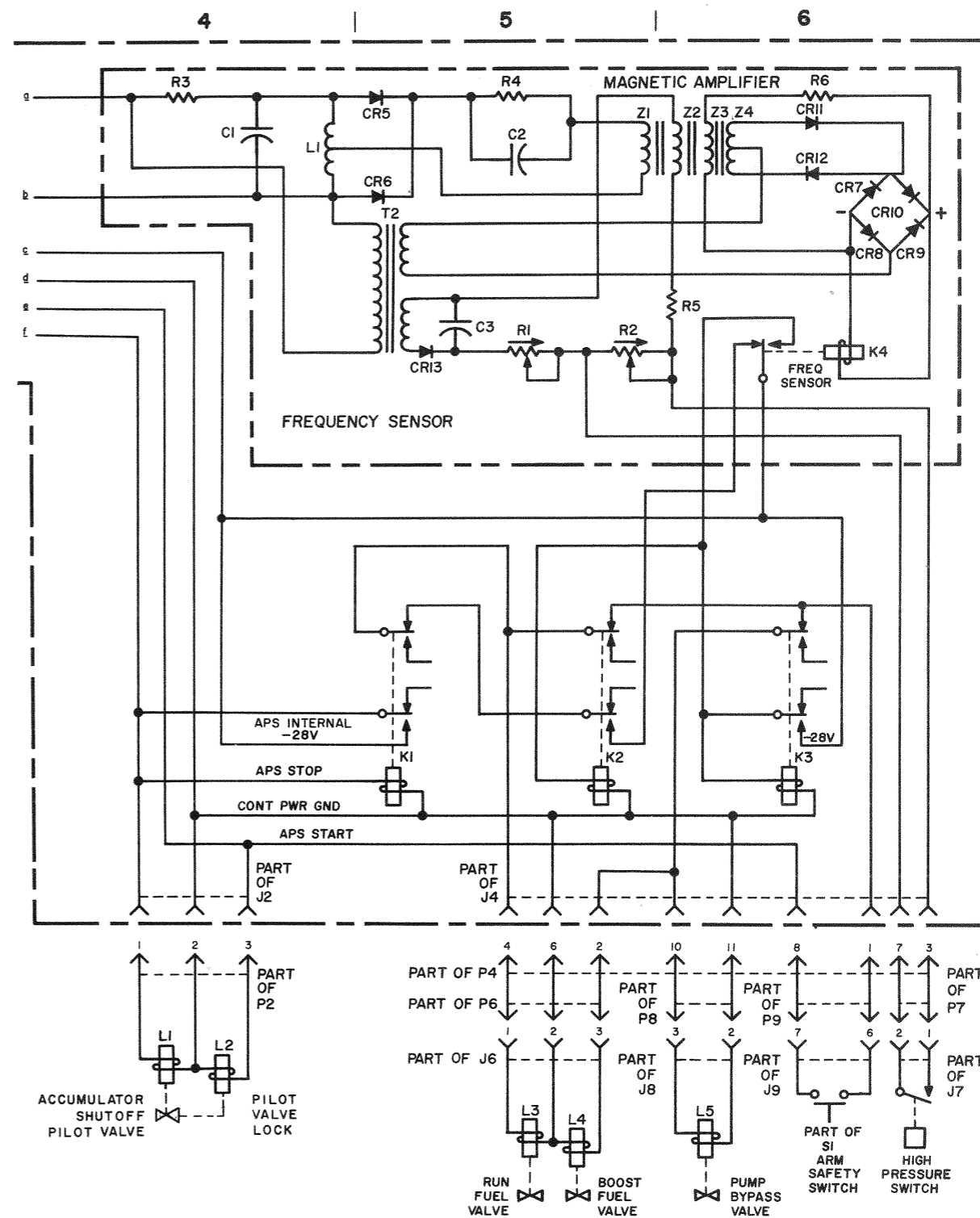
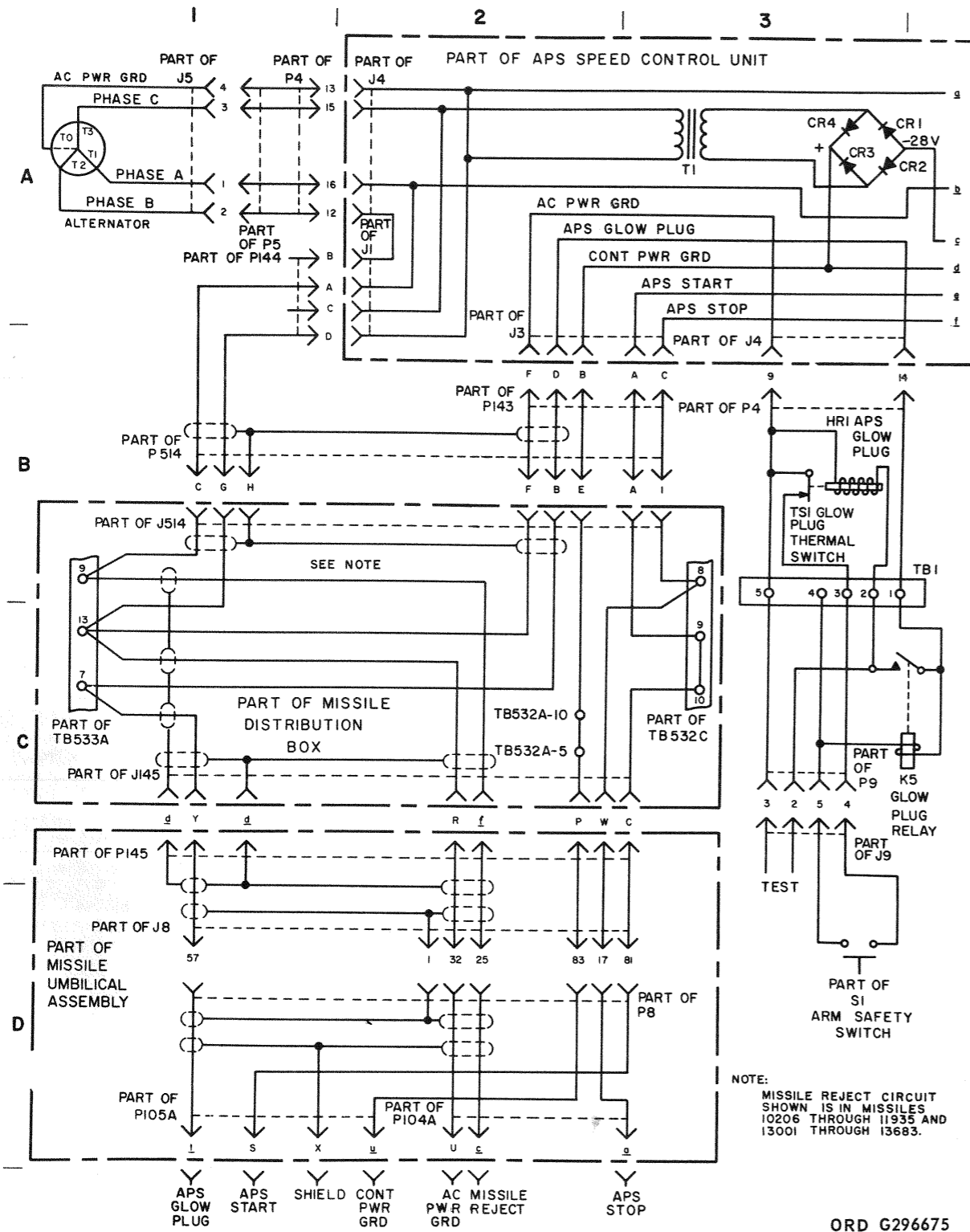
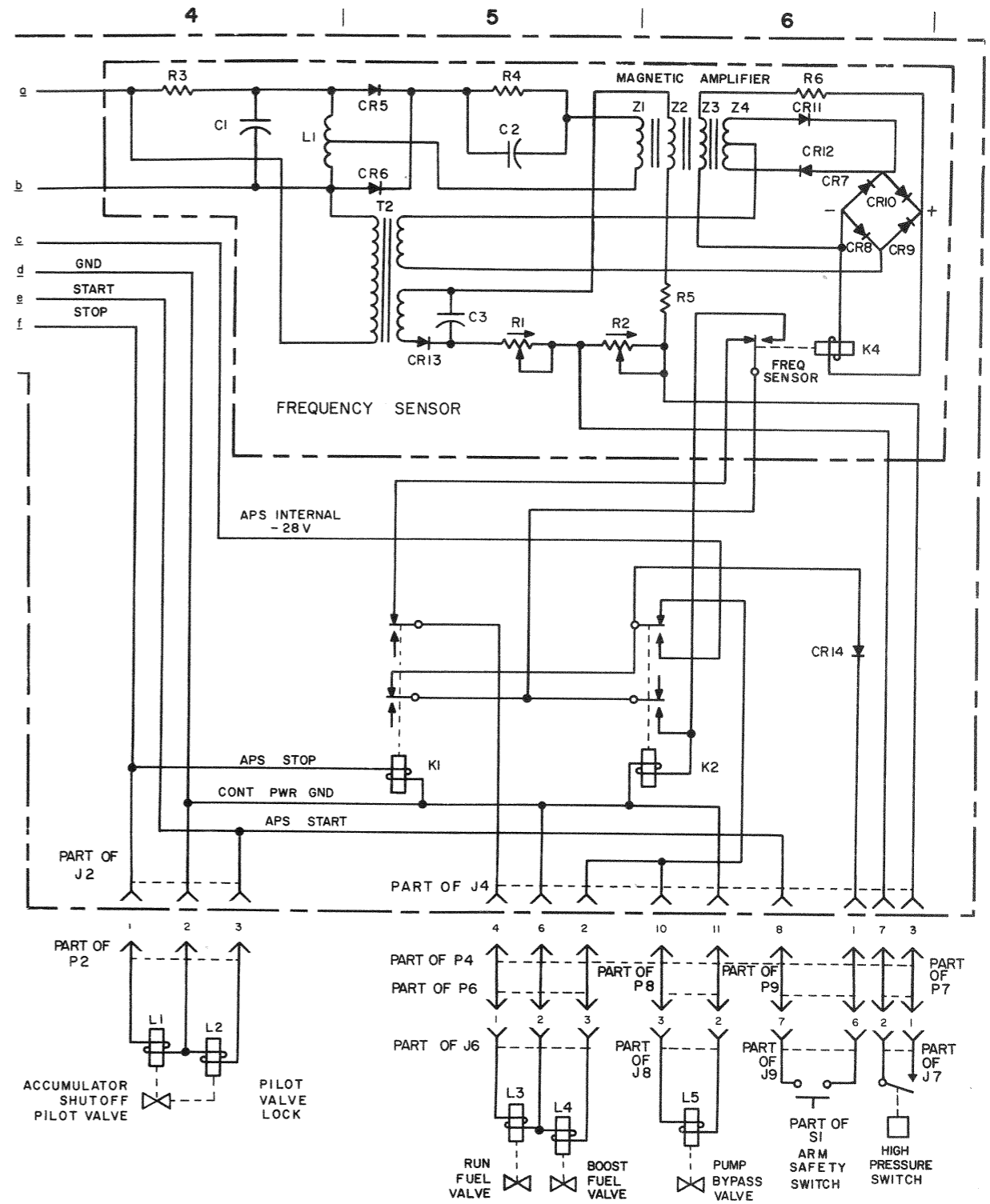

Figure 4-16 (U). Accessory power supply 9030900 electrical control system—functional schematic (serial numbers prior to 69-3632) (sheet 2 of 2) (U).

ORD G61210



ORD G296675



ORD G61211

Figure 4-17 (U). Accessory power supply 9030900 electrical control system—functional schematic (serial numbers 69-3632 and subsequent) (sheet 1 of 2) (U).

Figure 4-17 (U). Accessory power supply 9030900 electrical control system—functional schematic (serial numbers 69-3632 and subsequent) (sheet 2 of 2) (U).

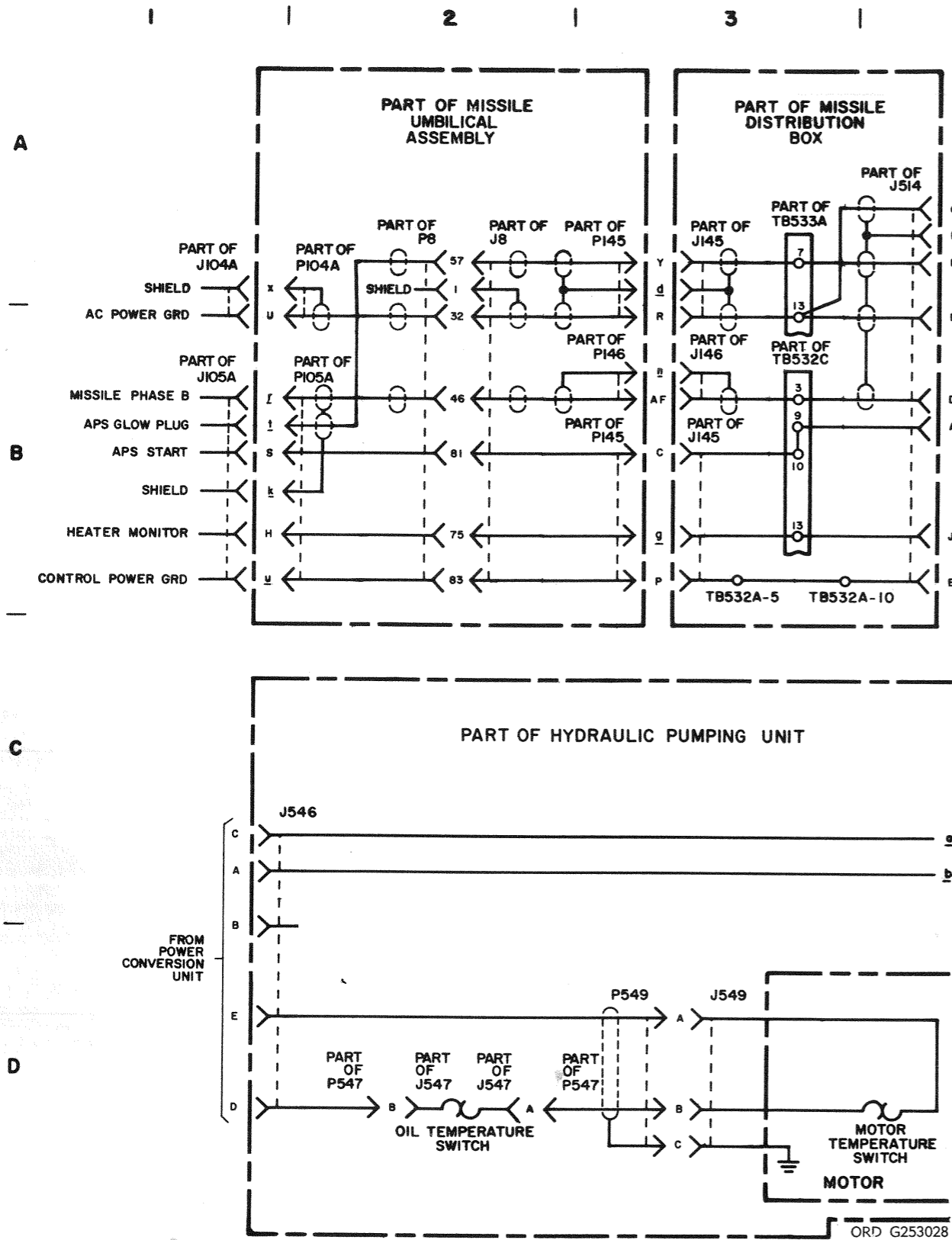

Figure 4-18 (U). Hydraulic pumping unit—functional schematic (sheet 1 of 2) (U).

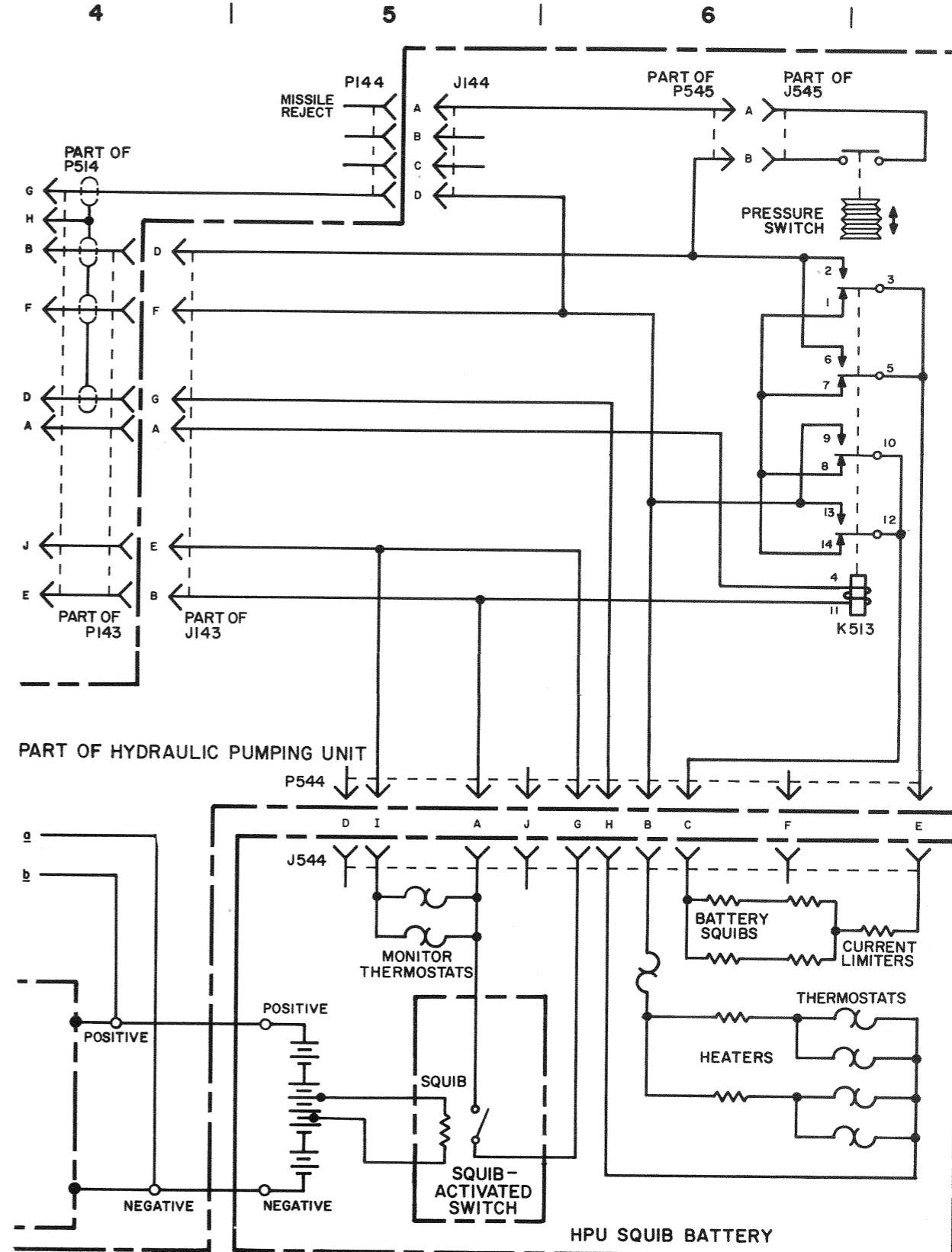

Figure 4-18 (U). Hydraulic pumping unit—functional schematic (sheet 2 of 2) (U).

ORD G296674

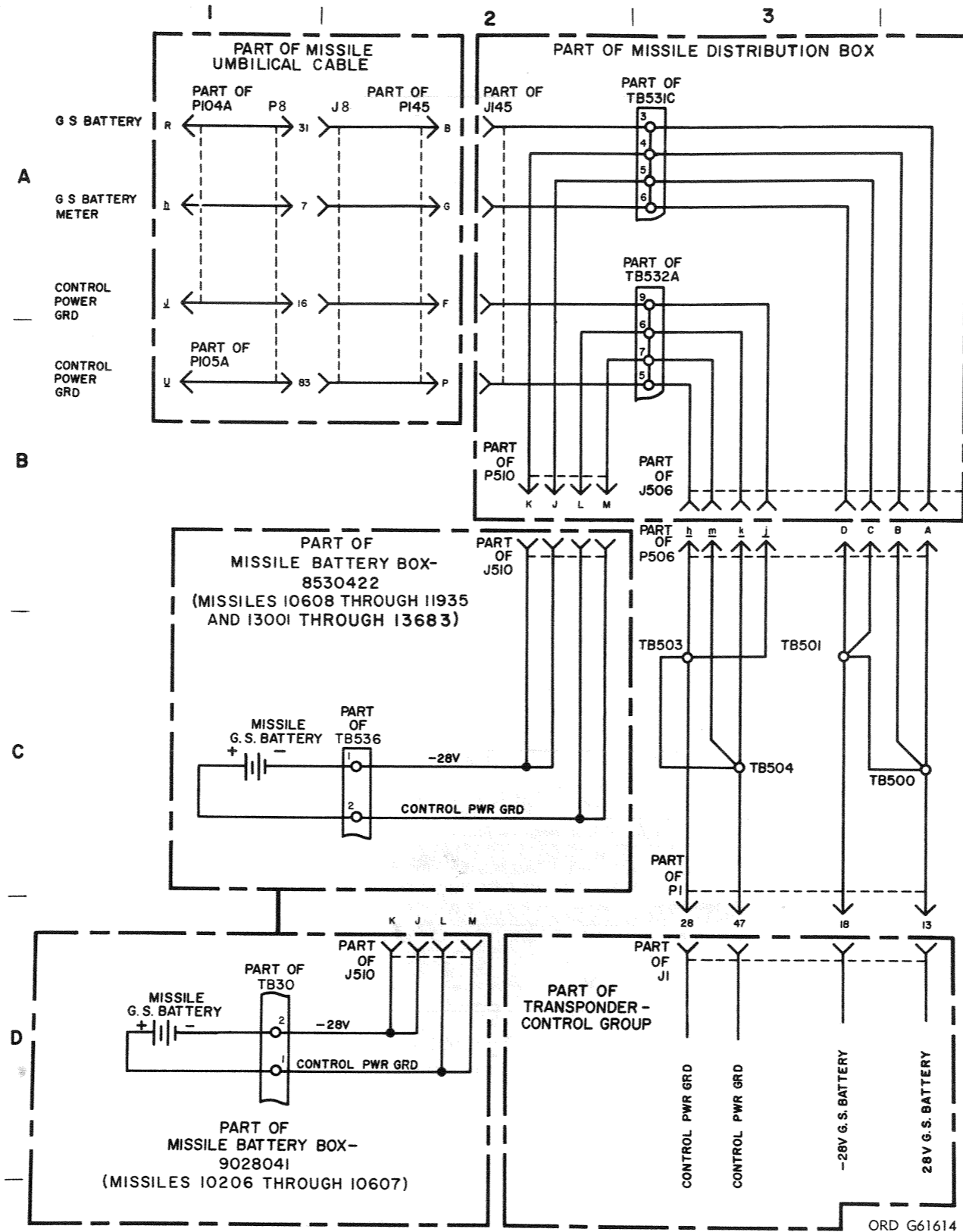

Figure 4-19 (U). Missile guidance set battery—functional schematic (U).

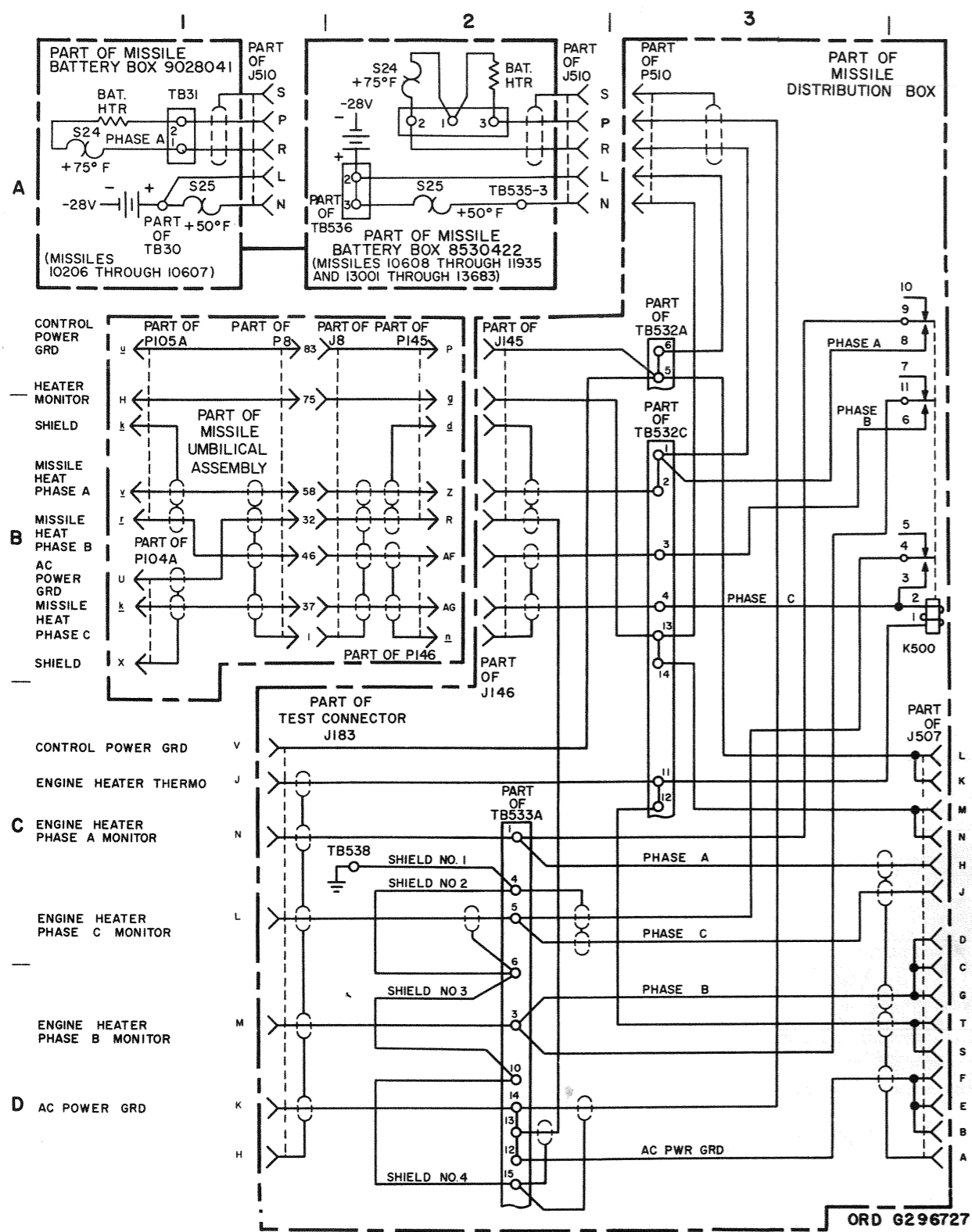

Figure 4-20 (U). Missile heater system—functional diagram (sheet 1 of 2) (U).

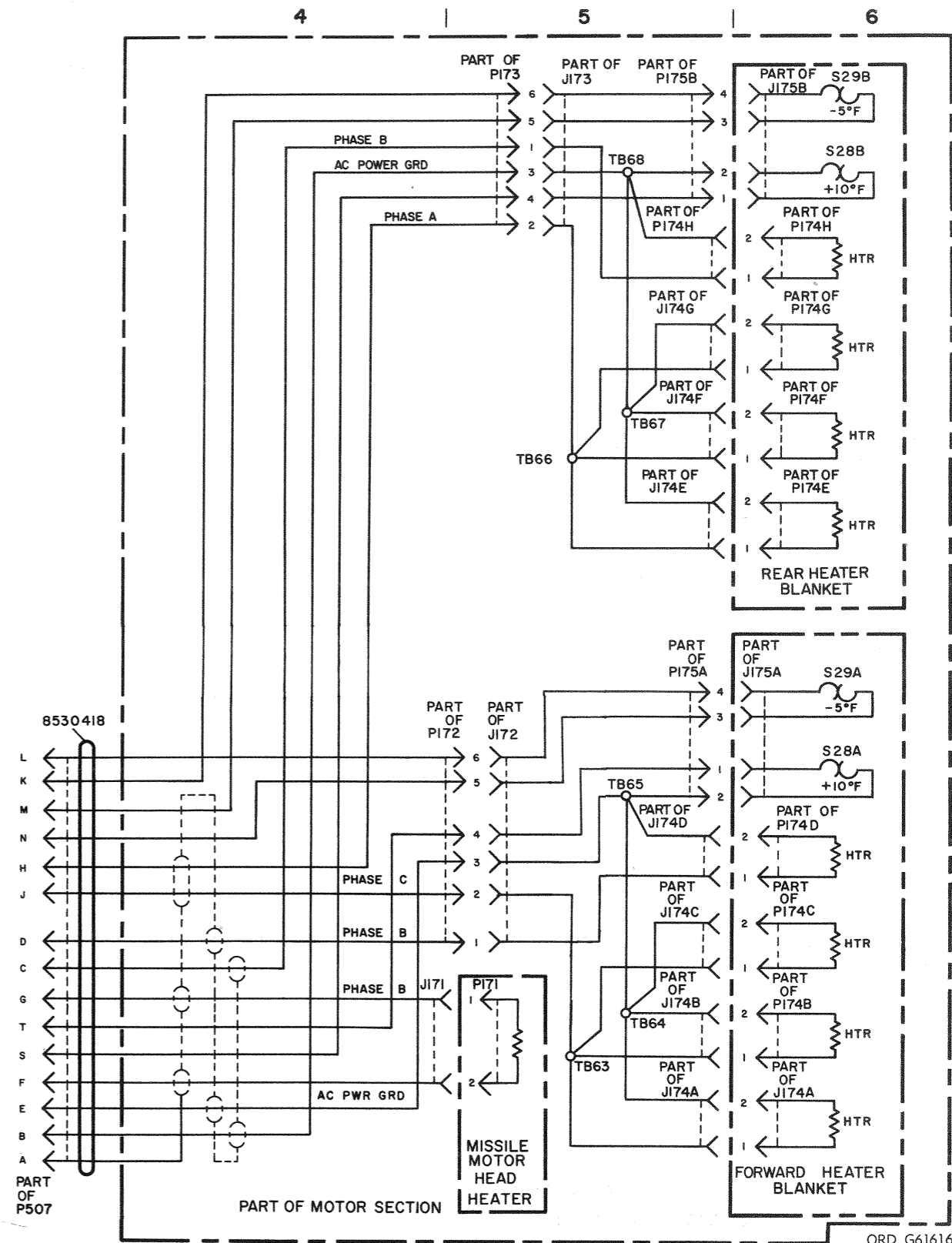
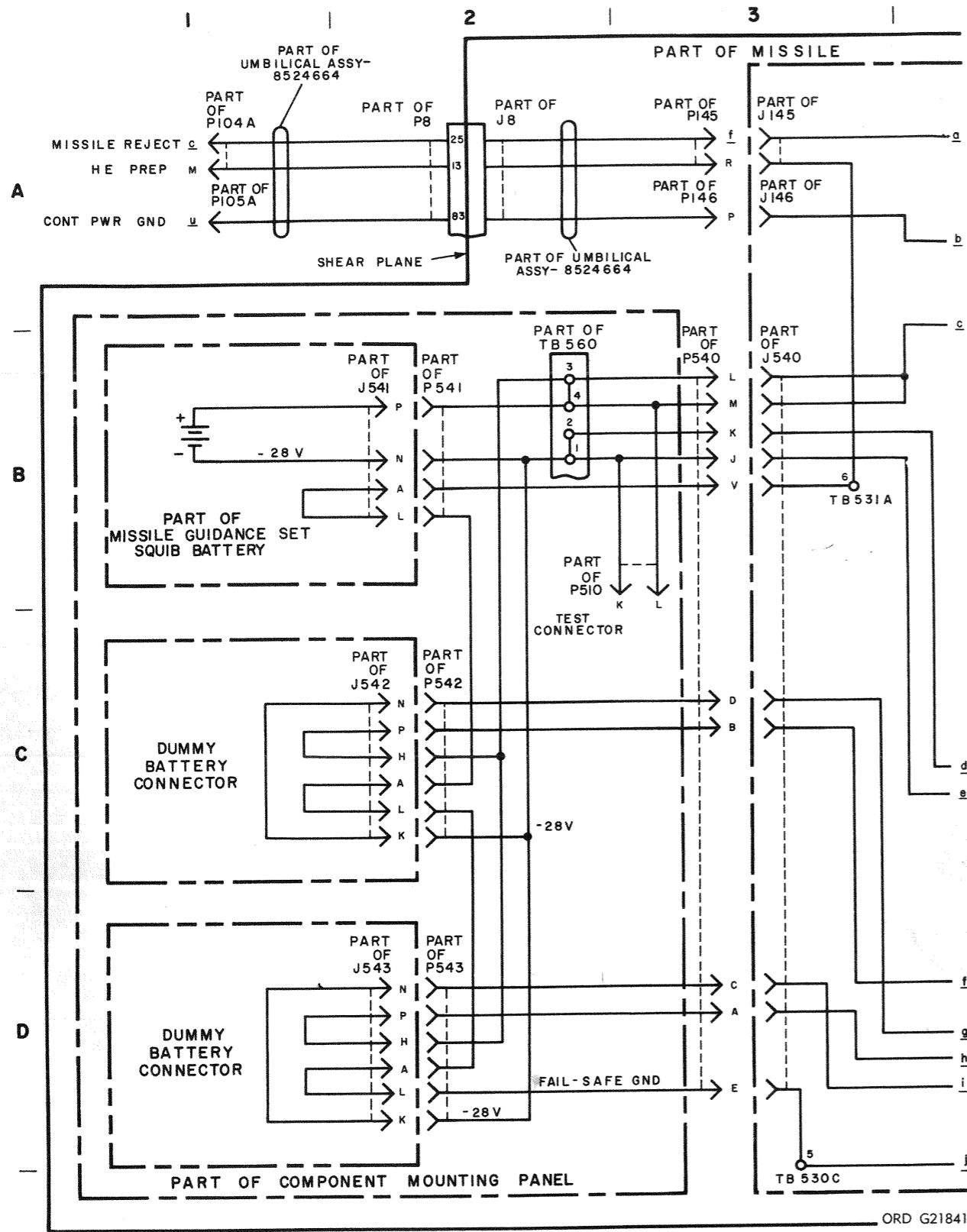

Figure 4-20 (U). Missile heater system—functional diagram (sheet 2 of 2) (U).





ORD G21841

Figure 4-21 (U). Missile guidance set battery, missile reject, and HE prepared circuits—functional diagram (missiles 13684 and subsequent) (sheet 1 of 2) (U).

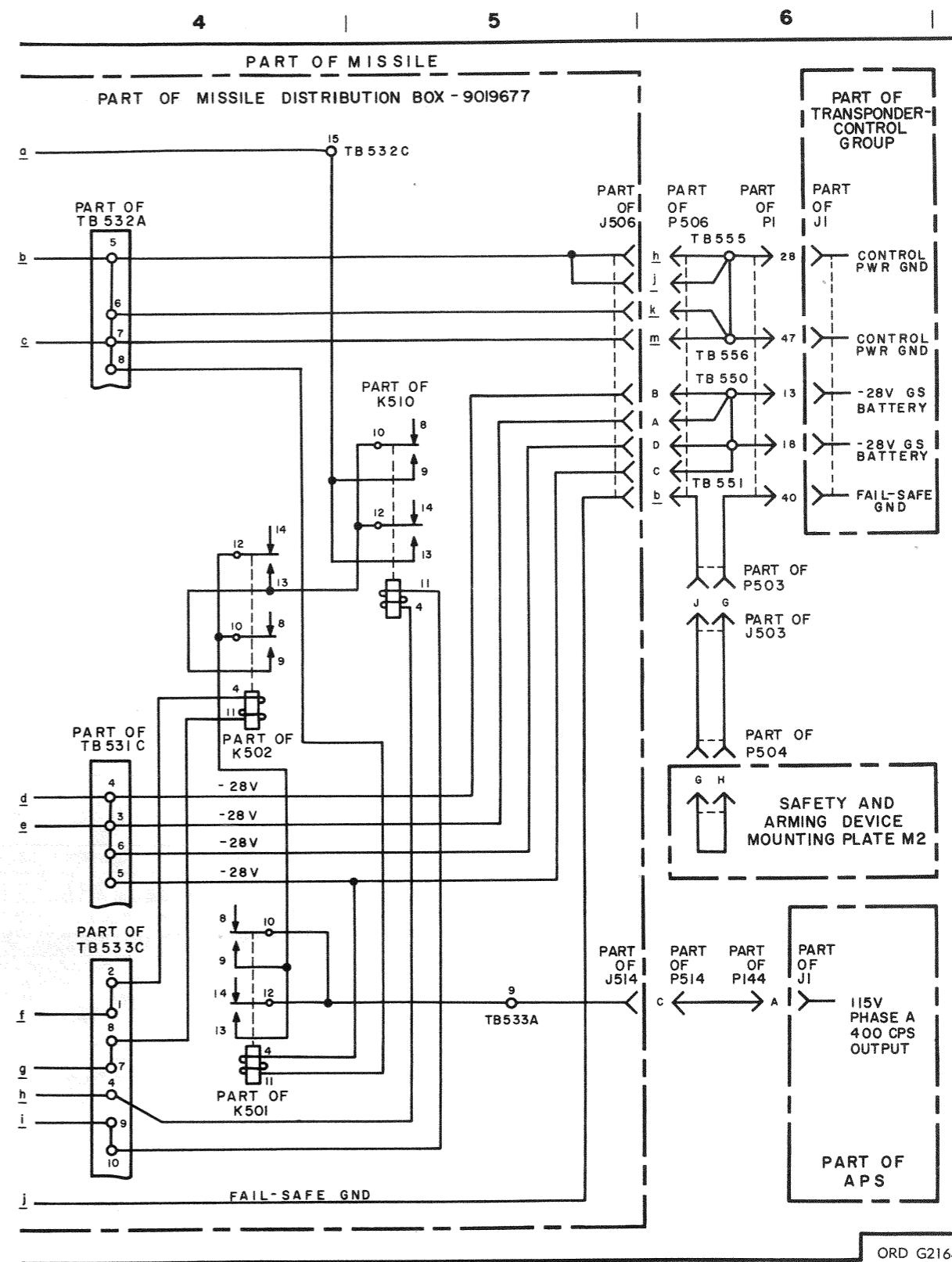

ORD G21641

Figure 4-21 (U). Missile guidance set battery, missile reject, and HE prepared circuits—functional diagram (missiles 13684 and subsequent) (sheet 2 of 2) (U).



**CONFIDENTIAL**

TM 9-1410-250-12/2

By Order of the Secretary of the Army:

**HAROLD K. JOHNSON,**  
*General, United States Army,*  
*Chief of Staff.*

Official:

**KENNETH G. WICKHAM,**  
*Major General, United States Army,*  
*The Adjutant General.*

Distribution:

To be distributed in accordance with DA Form 12-32, Section II, requirements for organizational maintenance applicable to the NIKE-HERCULES and IMPROVED NIKE-HERCULES missile systems.

**CONFIDENTIAL**